

You will discover why ALPOLIC®/fr Zinc composite material (ZCM) is the building material of the future as soon as you fabricate it. Our ZCM is as easy to fabricate as wood: no special tools are required. It can be curved, bent, routed, drilled, sawed, sheared, punched, trimmed and molded into complex shapes with conventional woodworking or metalworking tools. ALPOLIC®/fr ZCM's versatility makes it readily adaptable to many other standard systems that are available from a variety of vendors, including rout & return systems, glazed-in systems and creative custom systems. ALPOLIC®/fr ZCM is not recommended for use in an edge grip system. In addition, you can create complex assemblies with ALPOLIC®/fr ZCM in combination with support systems attached with structural adhesives.

With Zinc composite materials care must be taken to isolate the Zinc skins from dissimilar metals to prevent galvanic corrosion from occurring. Stainless steel fasteners are recommended and an isolating coating or shims should be used with the mounting extrusions.

Care also should be taken when handling the Zinc materials after removal of the protective film to prevent fingerprints and hand marks. Our ZCM panels have natural Zinc skins which will oxidize and patina over time.

For further design, detailing and fabrication guidance, please refer to the materials in this section, or go to www.alpolic-usa.com. For samples or a list of authorized ALPOLIC® fabricators, please call the ALPOLIC® Hotline toll-free at 1-800-422-7270, or e-mail us at info@alpolic.com.

Visual Consistency

Zinc is a natural metal and there will be variations in appearance from coil to coil. All panels for a building elevation should be fabricated from the same lot.

The natural Zinc surface will oxidize and some variation in appearance may be noticeable due to differences in the environment the panels are exposed to.

ALPOLIC®/fr ZCM is produced using VM Zinc's Quartz Zinc Coils. Please contact the ALPOLIC® Hotline at 1-800-422-7270, or e-mail us at info@alpolic.com for a copy of the ZCM panel warranty

ALPOLIC®/fr ZCM PROPERTIES

Product Dimensions

Width	38 inches / 965 mm
Length	146 inches / 3708 mm Custom lengths available
Thickness	4mm

Product Tolerance

Width	+/- 0.04 inches / 3 feet, +/- 1.0 mm / meter
Length	+/- 0.04 inches / 3 feet, +/- 1.0 mm / meter
Thickness	+2 mm / -.15 mm
Bow	Maximum 0.5% of the length and/or width
Squareness	Maximum 0.2"

Wind Load Deflection

Wind load deflection depends on the thickness, aspect ratio, span and boundary condition (whether ALPOLIC®/fr ZCM is simply supported or fixed). For more information and calculations for wind load and deflection please refer to the download section of ALPOLIC-USA.com.

For the 4 mm ZCM panel:

$$Eap * t_{ap}^3 = 16.27 * 10^3 \text{ lbf} * \text{in}$$

Thermal Expansion/Contraction

Thermal expansion/contraction must be considered when designing with ALPOLIC®/fr ZCM. To calculate thermal expansion/contraction, use the following equation:

$$\Delta T(\text{°F}) \times L(\text{feet}) \times \text{Cth} = \Delta T(\text{°F}) \times L(\text{feet}) \times \text{Cth}$$

Cth = Coefficient of thermal expansion
L = Length of ALPOLIC/fr ZCM panel

$\Delta T = T_a - T_i$ where T_a is the actual temperature and T_i is the temperature when ALPOLIC/fr ZCM was fabricated or installed. A positive ΔT indicates expansion and negative ΔT indicates contraction.

ZCM Coefficient of Thermal Expansion

Unit	Cth
10^{-6} in /in /Degree F	(P) 15 (T) 11
10^{-6} mm / mm / Degree C	(P) 28 (T) 20

P= Parallel to the rolling direction. T = Transverse to the rolling direction

Bond Integrity:

Peel Strength (ASTM D1781): 22.5 in-lb/in (100 N-m/m) minimum.

No degradation in bond performance after 8 hours of submersion in boiling water and after 21 days of immersion in water at 70 degrees F (21 degrees C).

Galvanic Corrosion:

Zinc's Corrosion potential is lower than other metals. Contact with steel, aluminum and copper, which have a higher corrosion potential, may cause accelerated corrosion of the Zinc metal under moist conditions. Stainless Steel forms an inactive layer and will not cause an accelerated corrosion of zinc.

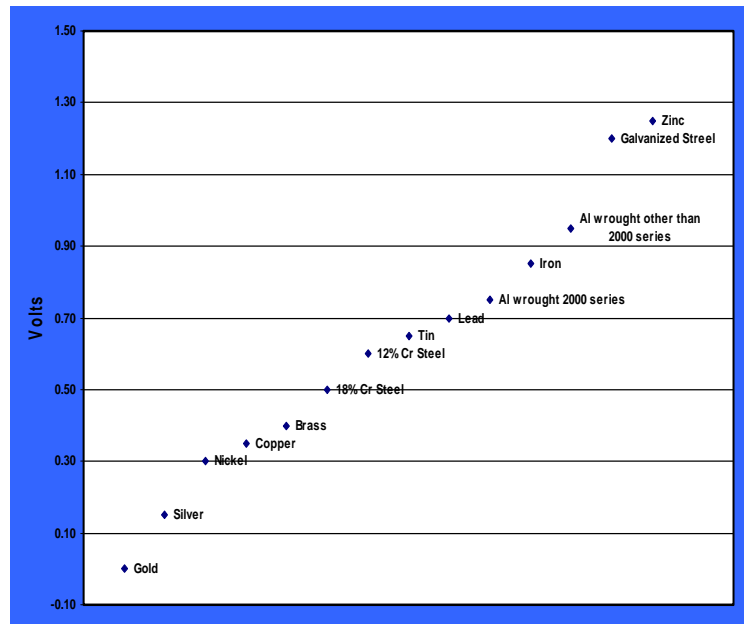

Impact resistance: (4 mm ZCM)

Steel Ball (0.5 Inch diameter)	Height (inches)	Dent Depth (inches) (mm)
2 lb / 0.9 Kg	6	0.028
2 lb / 0.9 Kg	12	0.035
2 lb / 0.9 Kg	18	0.042
2 lb / 0.9 Kg	24	0.056
2 lb / 0.9 Kg	36	0.095

Mechanical Properties:

Property	Unit	ASTM	4 mm ZCM
Elongation	%	E8	(P) 36.9 (T) 16.4
Yield Strength	psi	E8	(P) 4989 (T) 7054
Mean Flexural Strength	psi	C393	18495
Flexural Modulus	psi * 10 ⁶	C393	4.191
Mean Flexural Rigidity	lb _r -in ²	C393	1533

P= Parallel to the rolling direction. T = Transverse to the rolling direction

Physical Properties:

Property	Unit	4 mm ZCM
Zinc Thickness	mm	.5
Specific Gravity	-----	3.14
Weight	lbs/ ft ²	2.57

MECHANICAL PROCESSING

Cutting/Saw

ALPOLIC®/fr ZCM can be easily cut using standard woodworking saws (i.e. circular hand saw or panel saw). A carbide tip blade made for light metal and plastic is the most suitable for cutting ALPOLIC®/fr ZCM (Refer to next page).

Cutting/Shear

Square shear cutting is the easiest method for cutting large panels. Some shear droop may result at the cut part of the Zinc surface material.

For shear cutting ALPOLIC®/fr ZCM: recommended rake angle for shear cutting as listed below.

Thickness of ALPOLIC®	Clearance	Rake angle
4 mm	0.002"	1° 30'

Edge Finishing

When a smooth finished edge is required on ALPOLIC®/fr ZCM, the following equipment can be used to provide the specific requirements: woodworking planer or shaper, tenoning machine or milling machine.

The edging process provides smooth, crisp, clean edges, to insure clean joint intersections or to create a detailed frame effect when angled.

Processing

Because of ALPOLIC®/fr ZCM's composite makeup, the following process is required to fabricate sharp angle bends. This requires routing or cutting either a 'V' or 'U' groove in the ALPOLIC®/fr ZCM, as shown, to provide the required bend.

The 'U' or 'V' cut bottom should not reach to the back of the Zinc. Leave about 0.012" of polyethylene core.

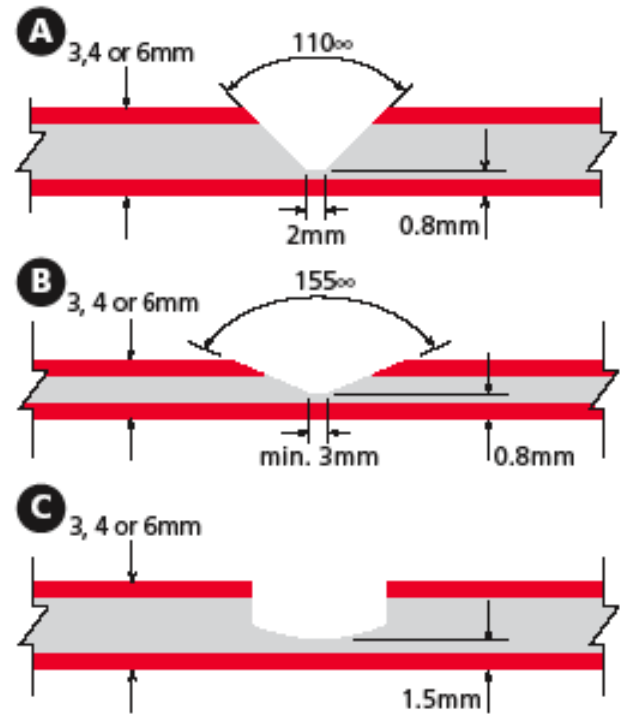

Router and Trimmer Tools

Use the bit as shown in the drawings below, which corresponds to the cut diagrams above.

Number of teeth	2 - 4
Rotation speed	20,000 - 30,000 rpm
Feeding speed	10 - 16 ft/min.
Material	Carbide

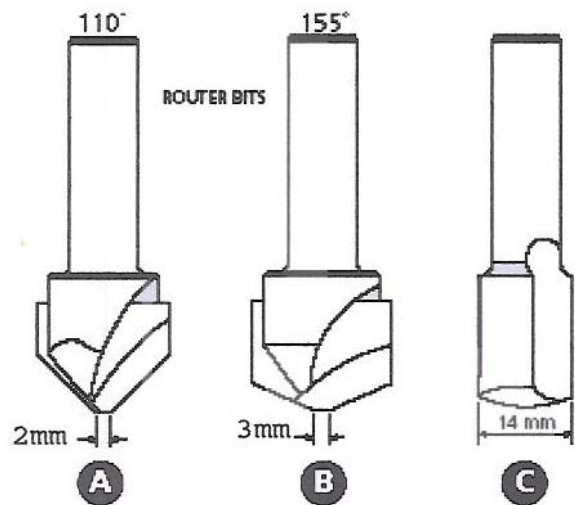

Saw/Milling Cutters

<i>Carbide Tip Saw Example</i>	
Outside diameter	12" 0
Number of teeth	36 (saw) 8 (grooving)
Rotation speed	3,000 - 5,000 rpm (variable motor)
Feeding speed	16 ft/min.

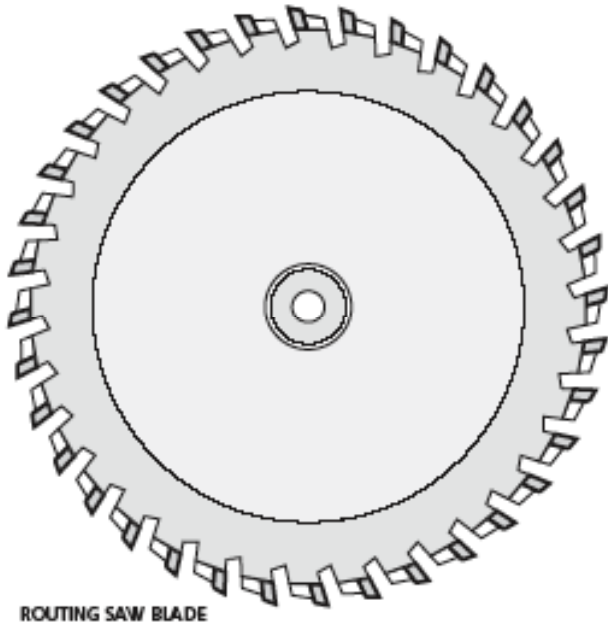

Bending

ALPOLIC[®]/frZCM should be processed on a flat surface, void of irregularities, to insure consistency in the depth of the 'V' or 'U' grooving. This will insure a smooth clean edge when bent.

If available, a plate or break press should be used to bend processed ALPOLIC[®]/fr ZCM. When this is not possible a simple bending jig made of wood or metal is recommended.

When ALPOLIC[®]/fr ZCM is processed with a 'V' groove and bent at 90°, the finished panel dimension will increase by approximately 1/8". This should be factored into the panel dimensions before final fabrication. It is advisable to do a preliminary test to insure the proper adjustment necessary.

All bending operations should be performed at a temperature above 55 degrees or the warranty may be void.

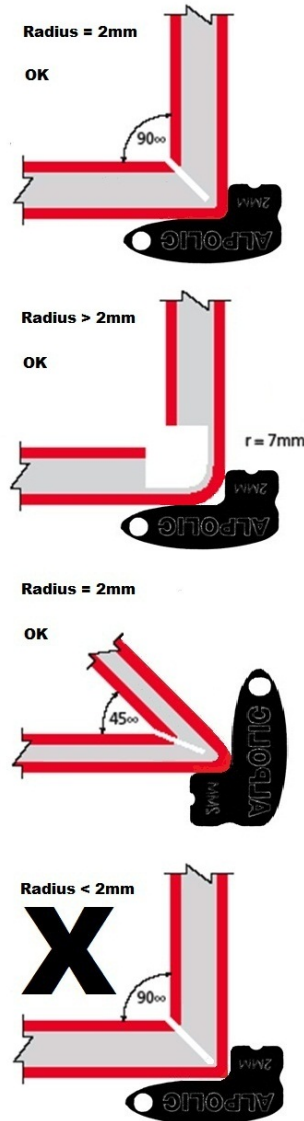

Curving

ALPOLIC[®]/fr ZCM can be easily curved using any of the following processes: Press Brake, Roll Bender, or Pipe Fixture.

The following are guidelines and limitations for curving ALPOLIC[®]/fr ZCM panels.

Press Brake

The minimum bending radius using a press brake is shown in the following table.

The Minimum Bending Radius with a Press Brake, 90° Bending and Internal Radius

Thickness of ALPOLIC [®]	Traverse (width)	Parallel (Length)
4 mm	1"	1 1/2"

Guidelines in bending process:

Because the Zinc surface material can be easily scratched, it is recommended that the following precautions be taken:

- To prevent scratches, a protective pad should be used on the die of the press brake.
- Pay attention to any scratches on the punch. It is recommended to use a fully polished punch.
- To prevent scratching, it is best to leave the factory applied protective film on the ALPOLIC®/fr ZCM during processing. Be sure there are no air bubbles or wrinkles before processing.
- With ALPOLIC®/fr ZCM, the volume of spring back varies somewhat in relationship to the bending direction, thickness, material temperature and the radius of the required bending angle.

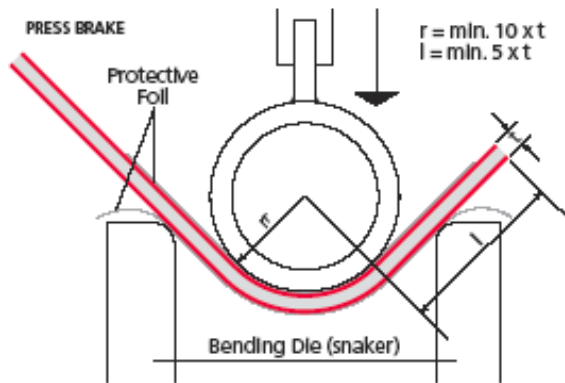

Bending with a Roller Bender:

A Roller Bender enables a larger bending radius than a press brake. The bending angle is determined by the diameter of the roll and the distance between the rolls. However a flat surface will appear at the beginning and the end of the panel. When this is not acceptable, it will be necessary to cut off and remove the flat surface in the finish fabrication process.

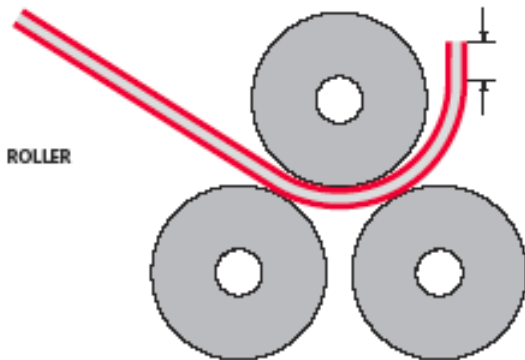

Bending with Clamped Pipe Fixture:

ALPOLIC®/fr ZCM can be bent over a pipe of the proper inside diameter that is securely clamped to a table. A hinged leaf attached to the end of the table will make bending easier. Initial bending beyond 90° may be required to compensate for any memory spring back.

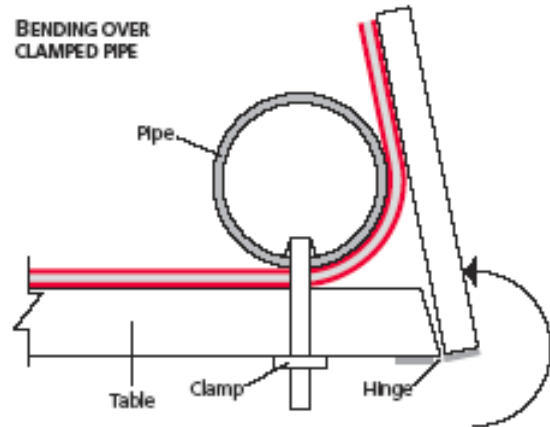

Punching/Drilling

Punching

Punching with a press sometimes causes shear droop in the Zinc surface material similar to shear cutting. It is preferable that the clearance of punch and die be made as small as possible (thickness of panel times 5%).

In the case of a small diameter hole (under 1/6") the tool may need to be modified as shown below to ensure that the polyethylene is completely removed in the process.

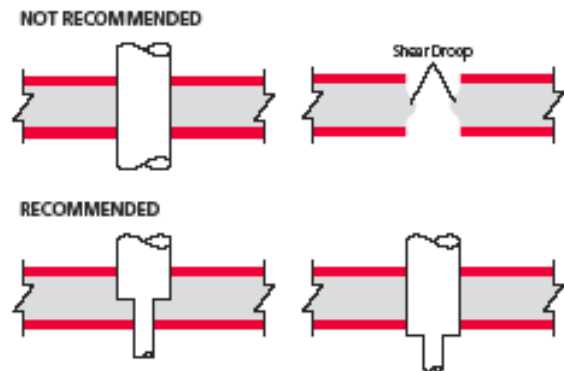

Drilling

ALPOLIC®/fr ZCM can be drilled with standard twist drills used for light metals and plastics.

WORKING SPECIFICATIONS:

- Drill bit: Twist drill, high speed steel.
- Tip Angle: 100-140 degrees, or counter-bore grind with centering tip.
- Cutting speed: 164 RPM to 984 RPM.

Quick removal of chips can be achieved by a high RPM, slow feed speed and occasional lifting of the bit.

ATTACHMENT CONCEPTS

Please reference the joint details diagrams in the download section on ALPOLIC-USA.com

JOINING ADHESION

Typical methods of joining ALPOLIC®/fr ZCM are the use of threaded fasteners, rivets, adhesives and double-faced high strength tapes. All fasteners must be of stainless steel. Proper consideration should be given to the thermal expansion characteristics of ALPOLIC®/fr ZCM,

Use the general guidelines listed below when other elements come in direct contact with the surface of ALPOLIC®/fr ZCM. When attaching the ZCM panels to dissimilar metals consideration needs to be given to the possible corrosion of joining surface due to electrolysis. If these materials must be used, make sure that a protective coating or separation exists between the two surfaces.

Threaded Fasteners

When using threaded fasteners, caution should be taken not to over tighten the fastener. The examples below show different threaded fastening methods.

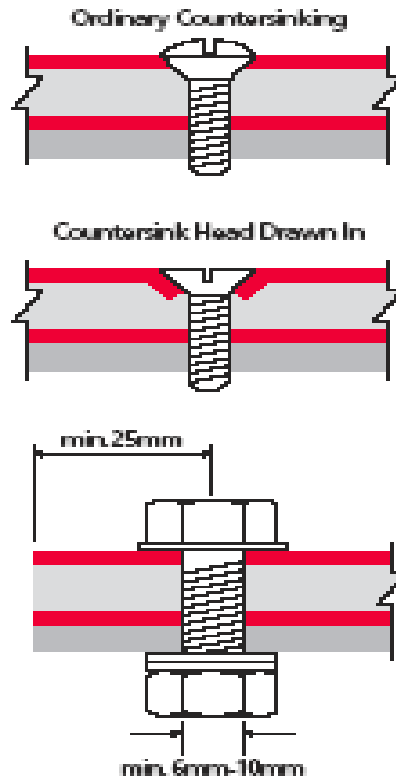

Rivets

Rivets can be used to fasten ALPOLIC®/fr ZCM panels together or to aluminum extrusion profiles. Rivets are especially suitable for fastening when vibration is likely. Stainless Steel rivets should be used. Colored plastic concealment caps can be used to conceal exposed rivet heads.

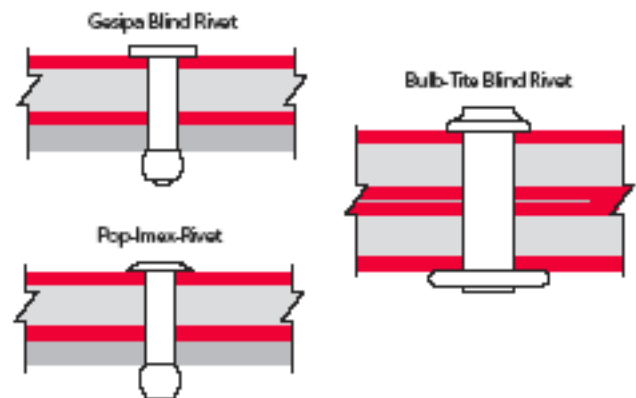

Adhesives & High Bond Tapes

When the ALPOLIC®/fr ZCM attachment surface is flat (i.e. wall, ceiling, sign board, etc.) construction adhesive or double-faced high bond tapes can be used for installation. See the technical bulletin on ALPOLIC and VHB tapes In the download section of ALPOLIC-USA.com. See recommended adhesive supplier for more details.

Welding/Hot Melt

Edge Preparation

ALPOLIC®/fr ZCM parts should have edges beveled to the corresponding angle of the finished part and allowing an exposed surface on the welded side.

Hot Melt

When using Hot Melt systems to bond ALPOLIC®/fr ZCM be sure that the surfaces to be bonded have been abraded and cleaned.

Hot Melt adhesives designed for bonding Zinc or similar metals are recommended. To insure the maximum bonding, please consult the adhesive manufacturer.

An application temperature of less than 350 degrees F is recommended to avoid any darkening of the zinc skins

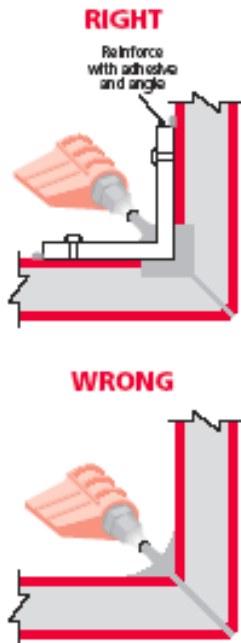

APPENDICES

Masking

ALPOLIC®/fr ZCM comes with a factory applied protective masking film which should be removed after fabrication.

Storage

ALPOLIC®/fr ZCM is packed in wooden crates and can usually be stacked up to four crates high.

When storing unpacked ALPOLIC®/fr ZCM observe the following guidelines:

- To prevent warping or bending, place it horizontally on pallet or other stand.
- Avoid stacking ALPOLIC®/fr ZCM of different sizes together, as the surface or panel can be scratched by the edges of the smaller pieces.
- Preferably, store them by size in racks.
- In storing them by leaning against the rack as shown below, lay a rubber mat underneath and lean the ALPOLIC®/fr ZCM closely against the fixed back-up material.

RACKING SYSTEM

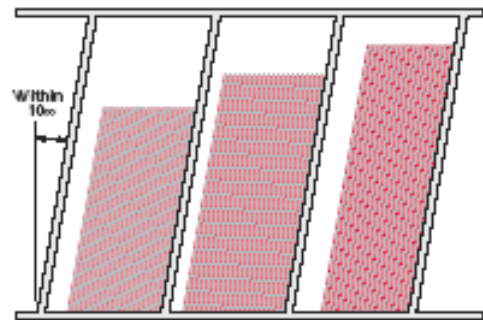

Cleaning

The skins of the ALPOLIC®/fr ZCM are natural Zinc. The Zinc skins will oxidize and patina with time. Cleaning is not recommended.